

# Aircraft Deicer

## GSS-1400

### General Specifications

Aviation GSE's GSS-1400 Aircraft Deicer features an approximate Pre-HEat to De Ice time of 20 minutes. The unit includes a 34.5-foot working height, and an articulating boom designed to service commuter and narrow-body aircraft. The GSS-1400 Deicer features a Deutz diesel engine and an efficient quick-rise heater system that burns up to 40% less fuel per operation.

- Length - 25 feet 4 inch (7.7 m)
- Width - 7 feet 8 inches (2.3 m)
- Height (Boom retracted) - 10 feet 3 inches (3.1 m)
- Wheelbase - 11 feet 3 inches (3.4 m)
- Max Working Height - 34 feet 6 inches (10.5m)
- Maximum Speed: 20 mph (32 km/h)
- De-Icing Fluid Pump: Myers I2C-20
- De-ice Fluid Delivery: 1200 gal Type 1 tank, 20-30 gpm @ 150 psi
- Anti-Icing Fluid Pump: Hardi Rotary Pump 363
- Anti-ice Fluid Delivery: 200 gal Type 4 tank, 20 gpm @50 psi
- Maximum Deice speed: 3 mph (5km/hr)
- Aerial Device: Articulating Boom
- Engine Manufacturer: Deutz Deisel (F4m2011)
- Fuel Tank: 50 gal.(189 L)
- GVW Empty Tanks: 13,500 lbs. (6124 kg)
- GVW Full Tanks: 24,800 lbs. (11249 kg)Cal

#### SAFETY FEATURES:

- Hydrostatic/Dynamic braking
- Open Basket
- Emergency stops in cab and basket.
- Emergency hydraulic pump control in basket and ground control station
- Boom control in basket and ground control station.
- High Speed Cutout When Boom is Raised
- Driver/Passenger seat belts.

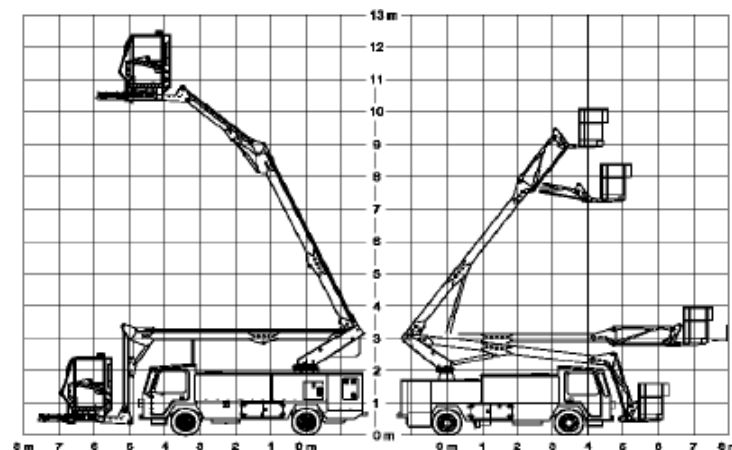

#### OPTIONAL FEATURES:

- Caterpillar 2.2 Diesel
- Hardi 363 De-Icing Fluid Pump
  - Type IV fill system
  - In Cab Flow Meters
- Full body safety harnesses.
  - Frost Gun
- Remote Tank Level Gauges
  - CE Certification